



堃霖空調
KUENLING A/C

CCTV 发现之旅 OUTLOOK 《華商論見》栏目展播企业

R-410A/R-507/R-404A

气冷冷藏/冷冻设备

5°C ~ -45°C

双段螺旋/往复冷凝机组

-25°C ~ -60°C

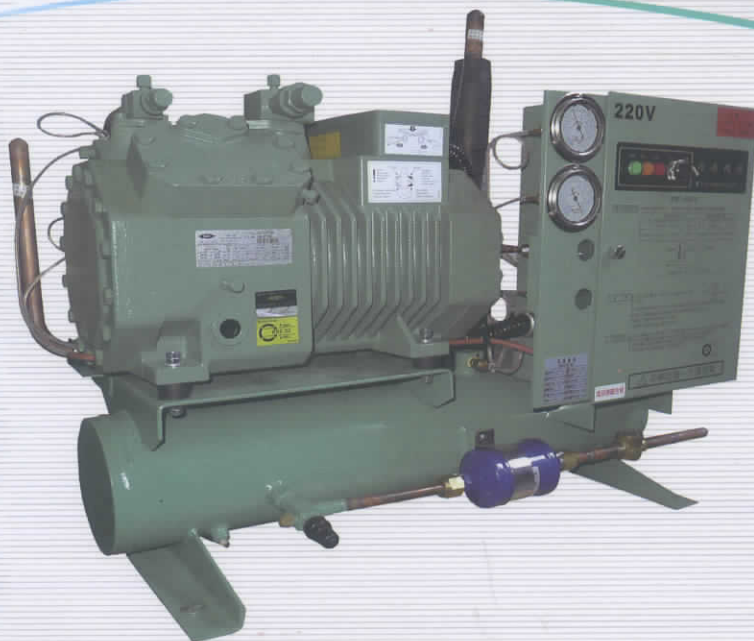

堃霖冷冻机械（上海）有限公司

KUEN LING MACHINERY REFRIGERATING(SHANGHAI) CO., LTD.

目录 Directory

特色.....	01
KHAC-H05SB 机组参数.....	02
KHAC-H10SB 机组参数.....	03
KHAC-H15SB 机组参数.....	04
KLAC-H20SB 机组参数.....	05
KHAC-L05SB 机组参数.....	06
KHAC-L10SB 机组参数.....	07
KHAC-L15SB 机组参数.....	08
KLAC-L20SB 机组参数.....	09
KLAC-D15SB 机组参数.....	10
KLAC-D20SB 机组参数.....	11
KLAC-D25SB 机组参数.....	12
KLAC-D30SB 机组参数.....	13
水冷式冷冻用双段冷凝机组参数.....	14-15
农畜/蔬菜水果类产品储存参考资料.....	16
海产/其他类产品储存参考资料.....	17

Handwritten signature: *Handwritten signature*

特色 Feature

环保

采用臭氧层破坏系数为0的环保冷媒: R-410A/ R-507/ R-404A

The units adopt environment friendly refrigerant R-410A/ R-507/ R-404A that the global warming potential(GWP) equal zero.

节能

使用高性能压缩机, 具有低噪音、低震动、高效率之特性, 设备体积小, 样式多可灵活搭配

The characteristic of compressor is low noise, low vibration and high efficiency. Small size and various of model for more flexible application.

高效率

配置高效率铜管之热交换器, 换热性能稳定, 提升部品性能优化让设备整体效能发挥到极致

Configuration of high efficiency copper tube heat exchangers, heat stable performance, enhance component performance optimization. Let play to the extreme of overall equipment effectiveness.

操作便利

采微电脑控制, 可显示设备目前状态且操作简易, LED数位式字体大, 清楚显示温度值

Mining microcomputer control, can display the current status of the device and is easy to operate, LED digital formula Large clear font display temperature.

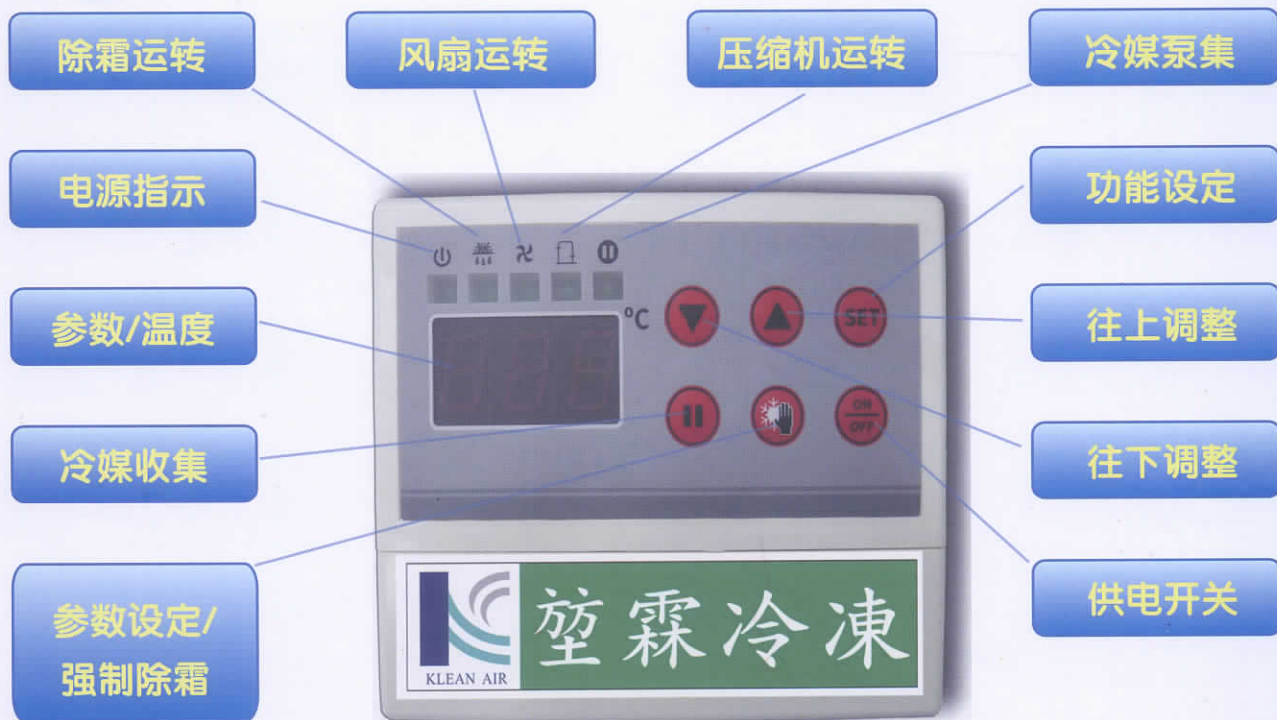

冷藏用冷凝机及冷风机

Condensing unit and cooler

R-410A/R507/R404A 冷藏用

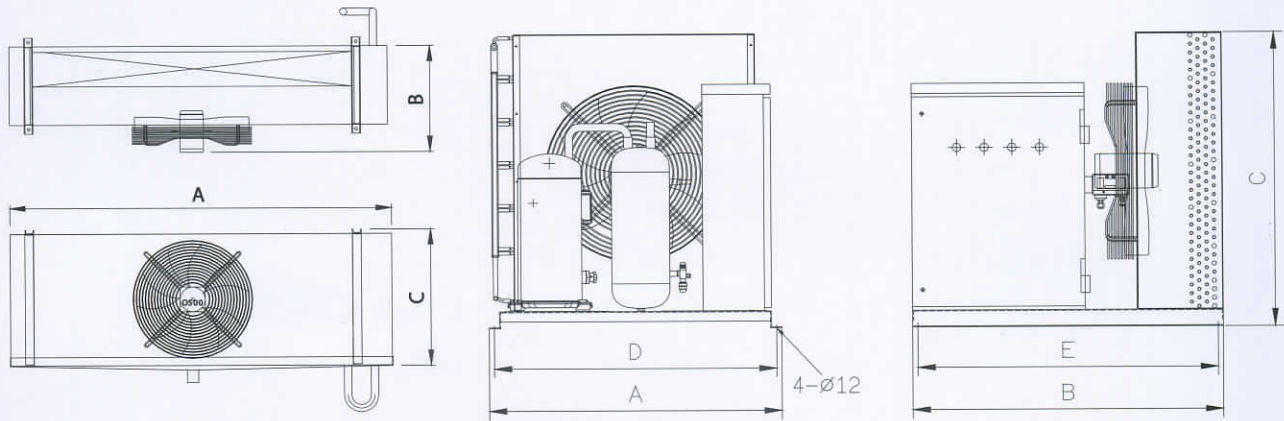

室外机机型		Outdoor unit model		KHAC-H05SB					
电源	Power source	V	3 ϕ - 380- 50Hz						
库温	Room temperature	°C	5°C	配管尺寸 Piping dim	液管 Liquid line	mm	9.52 (ϕ 3/8")		
冷却能力	Cooling capacity	kcal/hr	9,390 / 9,600		低压管 Suction line	mm	22.22 (ϕ 7/8")		
消耗电力	Power consumption	kW	4.1 / 4.7	附属配件 Accessories			视窗、干燥器、储液器 Sight glass , Dryer , Receiver		
压缩机 Compressor	型式 Type		全密闭式 Hermetic type						
	机数 Quantity		1						
	出力 Output	kW	3.8						
	起动方式 Start method		直接起动 Direct starting	保护装置 Protection devices	高低压开关、过载保护装置、 逆相保护器 High/low pressure switch, Overload pro				
	回转数 Revolution	r.p.m	2900						
油加热器 Oil heater	W	62							
冷冻油 Refrig. oil	种类 Type		POE-32	A	mm	850			
	填充量 Charge quantity	L	1.6	B	mm	900			
冷媒 Refrigerant	种类 Type		R410A / R-507 / R-404A	外型尺寸 Dimension			C	mm	870
	型式 Type		鳍片式 Fin-tube type				D	mm	820
冷凝器 Condenser	风扇数 Fan quantity		1	E	mm	870			
	散热风扇 Air flow rate	m ³ /min	85	机组重量 Operating weight		kg	85		
室内机型		Indoor unit model		KUC-H05S					
冷却能力	Cooling capacity	kcal/hr	9,658	外形尺寸 Dimension			A	mm	900
送风机 Fan	型式 Type		轴流式 Axial fan				B	mm	500
	风扇台数 Quantity		1	C	mm	710			
	扇叶外径 Fan size	Inch	20	排水管尺寸 Drain pipe size		Inch	1"		
	冷却风量 Air flow rate	m ³ /min	115	机组重量 Operating weight		kg	56		

1. 以上规格依外气温度35°CDB, 库内温度5°C
2. 压缩机及控制可依客户需求订制
3. 如有特殊要求, 订货前请提出要求规范, 以上规格如有变更, 恕不另行通知

冷藏用冷凝机及冷风机

Condensing unit and cooler

R-410A/R507/R404A 冷藏用

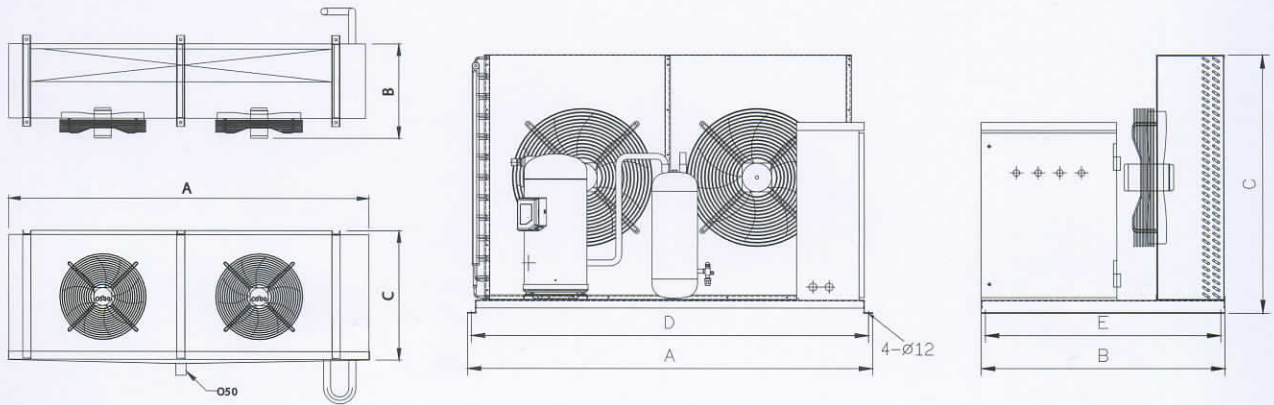

室外机机型	Outdoor unit model	KHAC-H10SB					
电源	Power source	V	3 ϕ - 380- 50Hz				
库温	Room temperature	°C	5°C	配管尺寸 Piping dim	液管 Liquid line	mm	15.88 (ϕ 5/8")
冷却能力	Cooling capacity	kcal/hr	20,700 / 19,950		低压管 Suction line	mm	28.58 (ϕ 1 3/8")
消耗电力	Power consumption	kW	8.3 / 9.3	附属配件 Accessories			视窗、干燥器、储液器 Sight glass, Dryer, Receiver
压缩机 Compressor	型式 Type		全密闭式 Hermetic type				
	机数 Quantity		1				
	出力 Output	kW	7.5				
	起动方式 Start method		直接起动 Direct starting				
	回转数 Revolution	r.p.m	2900				
油加热器 Oil heater	W	62					
冷冻油 Refrig. oil	种类 Type		POE-32	外型尺寸 Dimension	A	mm	1500
	填充量 Charge quantity	L	3.1		B	mm	900
冷媒 Refrigerant	种类 Type		R410A / R-507 / R-404A		C	mm	975
	型式 Type		鳍片式 Fin-tube type		D	mm	1470
冷凝器 Condenser	风扇数 Fan quantity		2		E	mm	870
	散热风扇 Air flow rate	m ³ /min	170	机组重量 Operating weight	kg	160	
室内机型	Indoor unit model	KUC-H10S					
冷却能力	Cooling capacity	kcal/hr	21,000	外形尺寸 Dimension	A	mm	2355
送风机 Fan	型式 Type		轴流式 Axial fan		B	mm	500
	风扇台数 Quantity		2		C	mm	710
	扇叶外径 Fan size	Inch	20	排水管尺寸 Drain pipe size	Inch	1"	
	冷却风量 Air flow rate	m ³ /min	230	机组重量 Operating weight	kg	156	

1. 以上规格依外气温度35°CDB, 库内温度5°C
2. 压缩机及控制可依客户需求订制
3. 如有特殊要求, 订货前请提出要求规范, 以上规格如有变更, 恕不另行通知

冷藏用冷藏机组及冷风机
Condensing unit and cooler

R-410A/R507/R404A 冷藏用

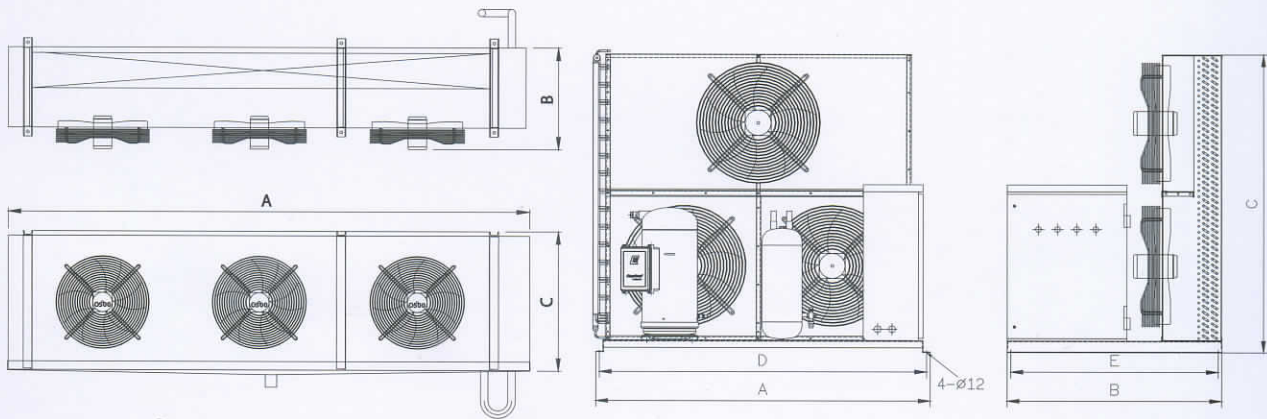

室外机机型	Outdoor unit model	KHAC-H15SB					
电源	Power source	V	3 ϕ - 380- 50Hz				
库温	Room temperature	°C	5°C	配管尺寸	液管	mm	15.88 (ϕ 5/8")
冷却能力	Cooling capacity	kcal/hr	31,250 / 27,100	配管尺寸	低压管	mm	28.58 (ϕ 1 3/8")
消耗电力	Power consumption	kW	12.1 / 14.1				
压缩机 Compressor	型式	Type	全密闭式 Hermetic type	附属配件			视窗、干燥器、储液器 Sight glass , Dryer , Receiver
	机数	Quantity	1				
	出力	Output	kW	11.1			
	起动方式	Start method	直接起动 Direct starting	保护装置			高低压开关、过载保护装置、 逆相保护器 High/low pressure switch, Overload pro
	回转数	Revolution	r.p.m	2900			
冷冻油 Refrig. oil	种类	Type	POE-32				
	填充量	Charge quantity	L	3.1	A	mm	1400
冷媒 Refrigerant	种类	Type	R-410A / R-507 / R-404A	外型尺寸			
	型式	Type	鳍片式 Fin-tube type	C	mm	1280	
	风扇数	Fan quantity	3	D	mm	1370	
冷凝器 Condenser	散热风扇	Air flow rate	m ³ /min	255	E	mm	870
				机组重量	Operating weight	kg	200
室内机型	Indoor unit model	KUC-H15S					
冷却能力	Cooling capacity	kcal/hr	31,500				
送风机 Fan	型式	Type	轴流式 Axial fan	外形尺寸			
	风扇台数	Quantity	3	A	mm	2475	
	扇叶外径	Fan size	Inch	20	B	mm	500
	冷却风量	Air flow rate	m ³ /min	345	C	mm	710
			排水管尺寸	Drain pipe size	Inch	2"	
			机组重量	Operating weight	kg	185	

1. 以上规格依外气温度35°CDB, 库内温度5°C
2. 压缩机及控制可依客户需求订制
3. 如有特殊要求, 订货前请提出要求规范, 以上规格如有变更, 恕不另行通知

冷藏用冷藏机组及冷风机
Condensing unit and cooler

R507/R404A 冷藏用

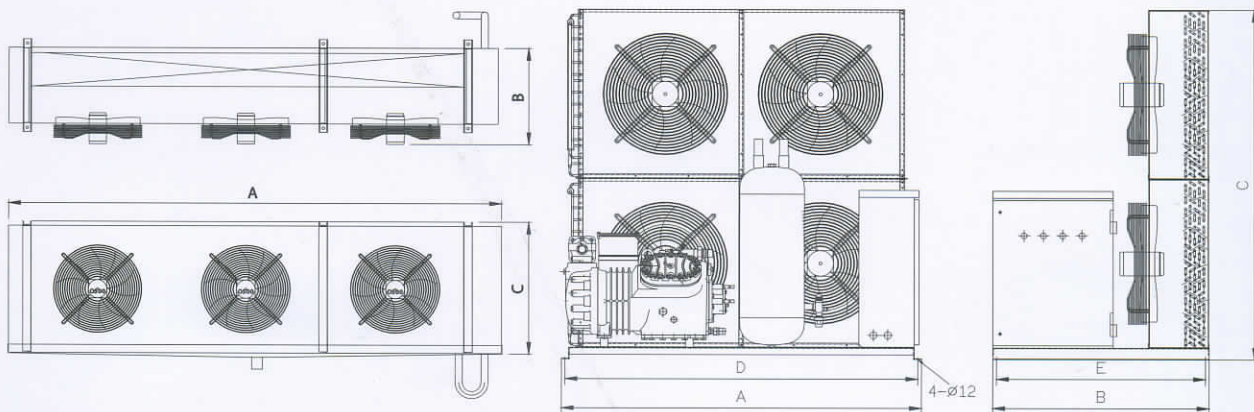

室外机机型		Outdoor unit model		KHAC-H20SB			
电源	Power source	V	3 ϕ - 380- 50Hz				
库温	Room temperature	$^{\circ}$ C	5 $^{\circ}$ C	配管尺寸 Piping dim	液管 Liquid line	mm	22.22 (ϕ 7/8")
冷却能力	Cooling capacity	kcal/hr	33,200		低压管 Suction line	mm	41.28 (ϕ 1 5/8")
消耗电力	Power consumption	kW	15.2	附属配件 Accessories			视窗、干燥器、储液器 Sight glass , Dryer , Receiver
压缩机 Compressor	型式 Type		全封闭式 Hermetic type				
	机数 Quantity		1				
	出力 Output	kW	14.9				
	起动方式 Start method		直接起动 Direct starting				
	回转数 Revolution	r.p.m	2900				
油加热器 Oil heater	W	140					
冷冻油 Refrig. oil	种类 Type		POE-32	外型尺寸 Dimension	A	mm	1500
	填充量 Charge quantity	L	2.6		B	mm	900
冷媒 Refrigerant	种类 Type		R-507 / R-404A	外型尺寸 Dimension	C	mm	1500
	型式 Type		鳍片式 Fin-tube type		D	mm	1470
冷凝器 Condenser	风扇数 Fan quantity		4	外型尺寸 Dimension	E	mm	870
	散热风扇 Air flow rate	m ³ /min	340		机组重量 Operating weight	kg	350
室内机型		Indoor unit model		KUC-H20S			
冷却能力	Cooling capacity	kcal/hr	33,500	外形尺寸 Dimension	A	mm	2475
送风机 Fan	型式 Type		轴流式 Axial fan		B	mm	650
	风扇台数 Quantity		3	C	mm	710	
	扇叶外径 Fan size	Inch	20	排水管尺寸 Drain pipe size	Inch	2"	
	冷却风量 Air flow rate	m ³ /min	345	机组重量 Operating weight	kg	225	

1. 以上规格依外气温度35 $^{\circ}$ CDB, 库内温度5 $^{\circ}$ C
2. 压缩机及控制可依客户需求订制
3. 如有特殊要求, 订货前请提出要求规范, 以上规格如有变更, 恕不另行通知

冷冻用冷冻机组及冷风机
Condensing unit and cooler

R507/R404A 冷冻

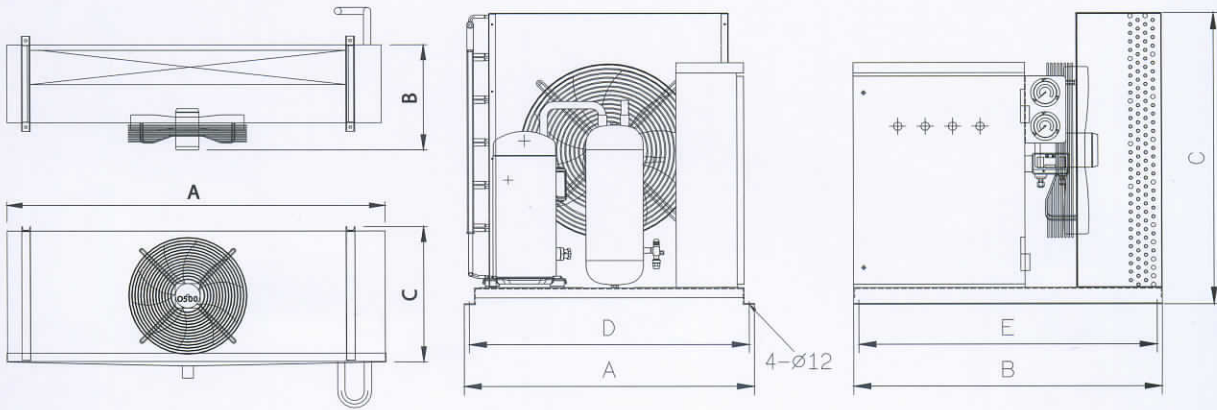

室外机机型		Outdoor unit model		KHAC-L05SB			
电源	Power source	V	3φ - 380- 50Hz				
库温	Room temperature	℃	-25℃	配管尺寸 Piping dim	液管 Liquid line	mm	9.52 (φ 3/8")
冷却能力	Cooling capacity	kcal/hr	2600		低压管 Suction line	mm	22.22 (φ 7/8")
消耗电力	Power consumption	kW	4.7	附属配件 Accessories			视窗、干燥器、储液器 Sight glass , Dryer , Receiver
压缩机 Compressor	型式 Type		全密闭式 Hermetic type				
	机数 Quantity		1				
	出力 Output	kW	3.8				
	起动方式 Start method		直接起动 Direct starting				
	回转数 Revolution	r.p.m	2900				
冷冻油 Refrig. oil	种类 Type		POE-32	外型尺寸 Dimension	A	mm	850
	填充量 Charge quantity	L	1.6		B	mm	900
冷媒 Refrigerant	种类 Type		R-507 / R-404A		C	mm	870
	型式 Type		鳍片式 Fin-tube type		D	mm	820
冷凝器 Condenser	风扇数 Fan quantity		1		E	mm	870
	散热风扇 Air flow rate	m ³ /min	85	机组重量 Operating weight	kg	85	
室内机型		Indoor unit model		KUC-L05S			
冷却能力	Cooling capacity	kcal/hr	3535	外形尺寸 Dimension	A	mm	900
送风机 Fan	型式 Type		轴流式 Axial fan		B	mm	500
	风扇台数 Quantity		1		C	mm	710
	扇叶外径 Fan size	Inch	20	排水管尺寸 Drain pipe size	Inch	1"	
	冷却风量 Air flow rate	m ³ /min	115	机组重量 Operating weight	kg	48	

1. 以上规格依外气温度35℃DB, 库内温度-25℃
2. 压缩机及控制可依客户需求订制
3. 如有特殊要求, 订货前请提出要求规范, 以上规格如有变更, 恕不另行通知

冷冻用冷冻机组及冷风机

Condensing unit and cooler

R507/R404A 冷冻

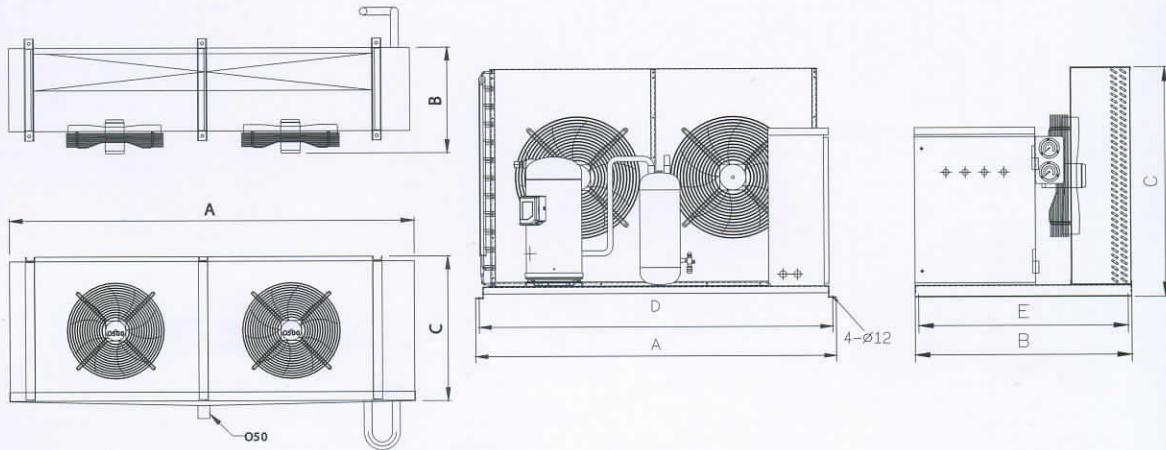

室外机机型		Outdoor unit model		KHAC-L10SB			
电源	Power source	V	3 ϕ - 380- 50Hz				
库温	Room temperature	$^{\circ}\text{C}$	-25 $^{\circ}\text{C}$	配管尺寸 Piping dim	液管 Liquid line	mm	15.88 (ϕ 5/8")
冷却能力	Cooling capacity	kcal/hr	5000		低压管 Suction line	mm	28.58 (ϕ 1 3/8")
消耗电力	Power consumption	kW	10.8	附属配件 Accessories			视窗、干燥器、储液器 Sight glass , Dryer , Receiver
压缩机 Compressor	型式 Type		全密闭式 Hermetic type				
	机数 Quantity		1				
	出力 Output	kW	7.5				
	起动方式 Start method		直接起动 Direct starting				
	回转数 Revolution	r.p.m	2900				
油加热器 Oil heater	W	62					
冷冻油 Refrig. oil	种类 Type		POE-32	外型尺寸 Dimension	A	mm	1500
	填充量 Charge quantity	L	3.1		B	mm	900
冷媒 Refrigerant	种类 Type		R-507 / R-404A		C	mm	975
	型式 Type		鳍片式 Fin-tube type		D	mm	1470
冷凝器 Condenser	风扇数 Fan quantity		2		E	mm	870
	散热风扇 Air flow rate	m ³ /min	170	机组重量 Operating weight		kg	160
室内机型		Indoor unit model		KUC-L10S			
冷却能力	Cooling capacity	kcal/hr	5180	外形尺寸 Dimension	A	mm	1950
送风机 Fan	型式 Type		轴流式 Axial fan		B	mm	550
	风扇台数 Quantity		2		C	mm	710
	扇叶外径 Fan size	Inch	20	排水管尺寸 Drain pipe size		Inch	1"
	冷却风量 Air flow rate	m ³ /min	230	机组重量 Operating weight		kg	156

1. 以上规格依外气温度35 $^{\circ}\text{C}$ DB, 库内温度-25 $^{\circ}\text{C}$
2. 压缩机及控制可依客户需求订制
3. 如有特殊要求, 订货前请提出要求规范, 以上规格如有变更, 恕不另行通知

冷冻用冷冻机组及冷风机

Condensing unit and cooler

R507/R404A 冷冻

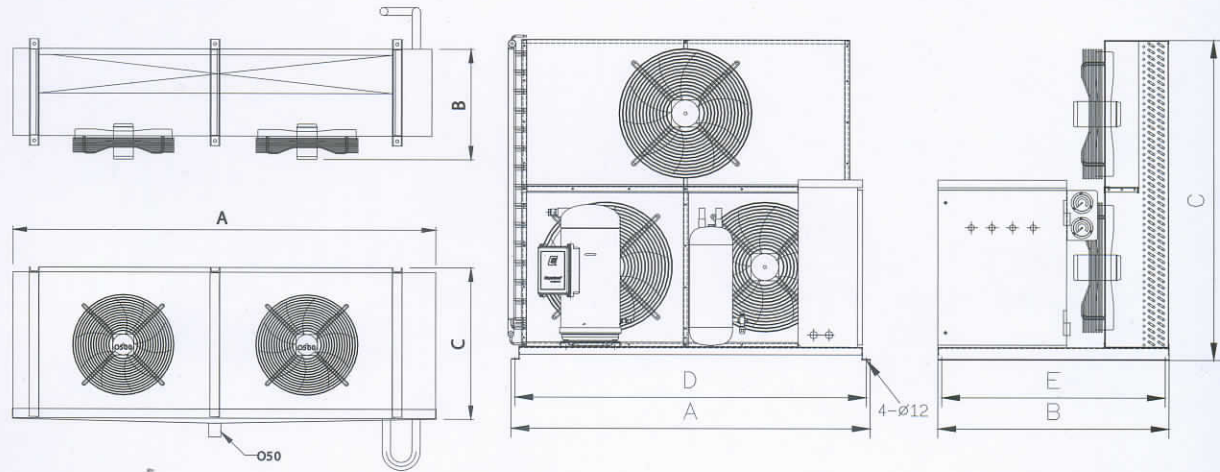

室外机机型	Outdoor unit model	KHAC-L15SB						
电源	Power source	V	3 ϕ - 380- 50Hz					
库温	Room temperature	$^{\circ}\text{C}$	-25 $^{\circ}\text{C}$	配管尺寸	液管	mm	15.88 (ϕ 5/8")	
冷却能力	Cooling capacity	kcal/hr	6700	Piping dim	低压管	mm	28.58 (ϕ 1 3/8")	
消耗电力	Power consumption	kW	14.6	附属配件 Accessories			视窗、干燥器、储液器	
压缩机 Compressor	型式	Type	全密闭式 Hermetic type				保护装置 Protection devices	
	机数	Quantity	1					
	出力	Output	kW	11.1				
	起动方式	Start method		直接起动 Direct starting				
	回转数	Revolution	r.p.m	2900				
	油加热器	Oil heater	W	62				
冷冻油 Refrig. oil	种类	Type	POE-32	外型尺寸 Dimension	A	mm	1400	
	填充量	Charge quantity	L		3.1	B	mm	900
冷媒 Refrigerant	种类	Type	R-507 / R-404A	外型尺寸 Dimension	C	mm	1280	
	型式	Type	鳍片式 Fin-tube type		D	mm	1370	
	风扇数	Fan quantity			3	E	mm	870
冷凝器 Condenser	散热风扇	Air flow rate	m ³ /min	255	机组重量	Operating weight	kg	180
室内机型	Indoor unit model	KUC-L15S						
冷却能力	Cooling capacity	kcal/hr	7430	外形尺寸 Dimension	A	mm	1950	
送风机 Fan	型式	Type	轴流式 Axial fan		B	mm	600	
	风扇台数	Quantity			2	C	mm	710
	扇叶外径	Fan size	Inch	20	排水管尺寸	Drain pipe size	Inch	2"
	冷却风量	Air flow rate	m ³ /min	230	机组重量	Operating weight	kg	180

1. 以上规格依外气温度35 $^{\circ}\text{C}$ DB, 库内温度-25 $^{\circ}\text{C}$
2. 压缩机及控制可依客户需求订制
3. 如有特殊要求, 订货前请提出要求规范, 以上规格如有变更, 恕不另行通知

冷冻用冷冻机组及冷风机
Condensing unit and cooler

R507/R404A 冷冻

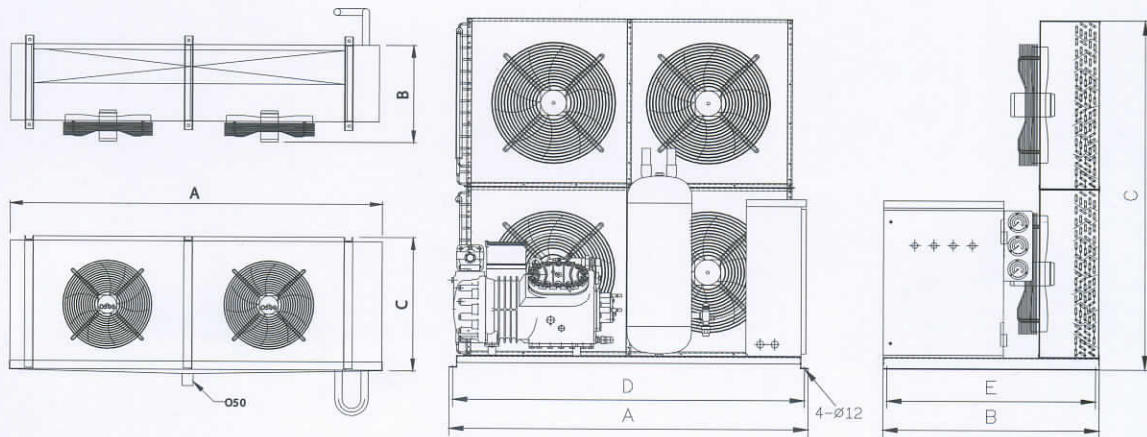

室外机机型	Outdoor unit model	KHAC-L20SB							
电源	Power source	V	3 ϕ - 380- 50Hz						
库温	Room temperature	$^{\circ}$ C	-25 $^{\circ}$ C	配管尺寸 Piping dim	液管 Liquid line	mm	22.22 (ϕ 7/8")		
冷却能力	Cooling capacity	kcal/hr	7000		低压管 Suction line	mm	41.28 (ϕ 1 5/8")		
消耗电力	Power consumption	kW	6.9	附属配件 Accessories			视窗、干燥器、储液器 Sight glass , Dryer , Receiver		
压缩机 Compressor	型式 Type		全密闭式 Hermetic type					保护装置 Protection devices	
	机数 Quantity		1						
	出力 Output	kW	14.9						
	启动方式 Start method		直接启动 Direct starting						
	回转数 Revolution	r.p.m	2900						
油加热器 Oil heater	W	140		外型尺寸 Dimension			机组重量 Operating weight		
冷冻油 Refrig. oil	种类 Type		BSE-32					A	mm
冷媒 Refrigerant	填充量 Charge quantity	L	2.6	B	mm	900			
	种类 Type		R-507 / R-404A	C	mm	1500			
	型式 Type		鳍片式 Fin-tube type	D	mm	1470			
冷凝器 Condenser	风扇数 Fan quantity		4	E	mm	870			
	散热风扇 Air flow rate	m ³ /min	340				350		
室内机型	Indoor unit model	KUC-L20S							
冷却能力	Cooling capacity	kcal/hr	9550	外形尺寸 Dimension			A	mm	1950
送风机 Fan	型式 Type		轴流式 Axial fan				B	mm	700
	风扇台数 Quantity		2	C	mm	710			
	扇叶外径 Fan size	Inch	20	排水管尺寸 Drain pipe size	Inch	1"			
	冷却风量 Air flow rate	m ³ /min	230	机组重量 Operating weight	kg	230			

1. 以上规格依外气温度35 $^{\circ}$ C DB, 库内温度-25 $^{\circ}$ C
2. 压缩机及控制可依客户需求订制
3. 如有特殊要求, 订货前请提出要求规范, 以上规格如有变更, 恕不另行通知

冷冻用双段冷冻机组

Condensing unit and cooler

R507/R404A 冷冻

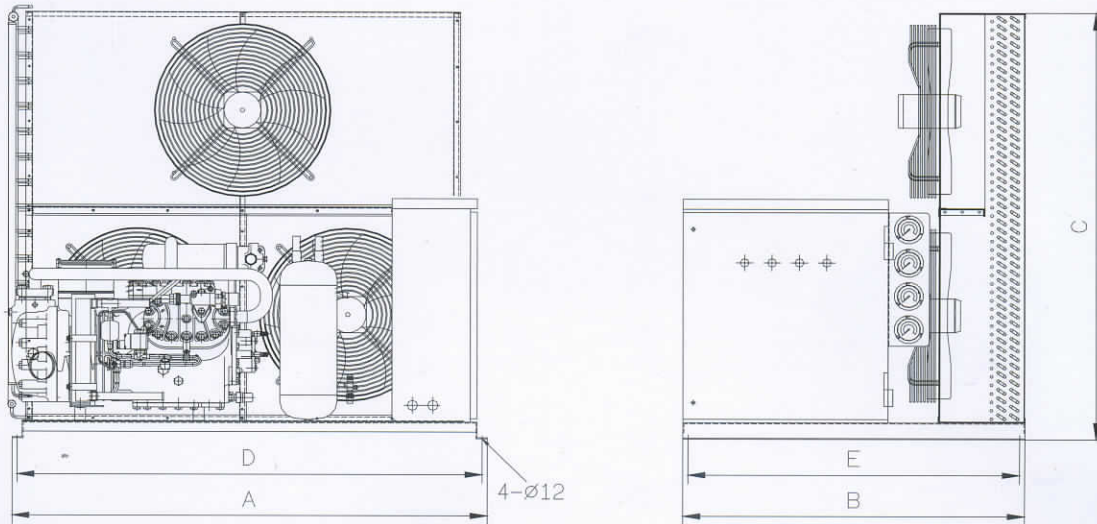

室外机机型		Outdoor unit model		KLAC-D15SB				
电源	Power source	V	3φ - 380- 50Hz					
库温	Room temperature	℃	-45℃	配管尺寸 Piping dim	液管 Liquid line	mm	15.88 (φ 5/8")	
冷却能力	Cooling capacity	kcal/hr	7990		低压管 Suction line	mm	41.28 (φ 1 5/8")	
消耗电力	Power consumption	kW	11.1	附属配件 Accessories		视窗、干燥器、储液器 Sight glass , Dryer , Receiver		
压缩机 Compressor	型式	Type	双段半密往复式 Two-stage Semi-hermetic Reciprocating					
	机数	Quantity	1					
	出力	Output	kW	11.1	保护装置 Protection devices		高低压开关、过载保护装置、 逆相保护器 High/low pressure switch, Overload pro	
	起动方式	Start method	直接起动 Direct starting					
	回转数	Revolution	r.p.m	2900				
	油加热器	Oil heater	W	140				
冷冻油 Refrig. oil	种类	Type	BSE-32	外型尺寸 Dimension	A	mm	1400	
	填充量	Charge quantity	L		4.8	B	mm	900
冷媒 Refrigerant	种类	Type	R-507 / R-404A	C	mm	1280		
冷凝器 Condenser	型式	Type	鳍片式 Fin-tube type	D	mm	1370		
	风扇数	Fan quantity	3	E	mm	970		
	散热风扇	Air flow rate	m ³ /min	255	机组重量 Operating weight		kg	380

1. 以上规格依外气温度35℃DB, 库内温度-45℃
2. 压缩机及控制可依客户需求订制
3. 如有特殊要求, 订货前请提出要求规范, 以上规格如有变更, 恕不另行通知

冷冻用双段冷冻机组

Condensing unit and cooler

R507/R404A 冷冻

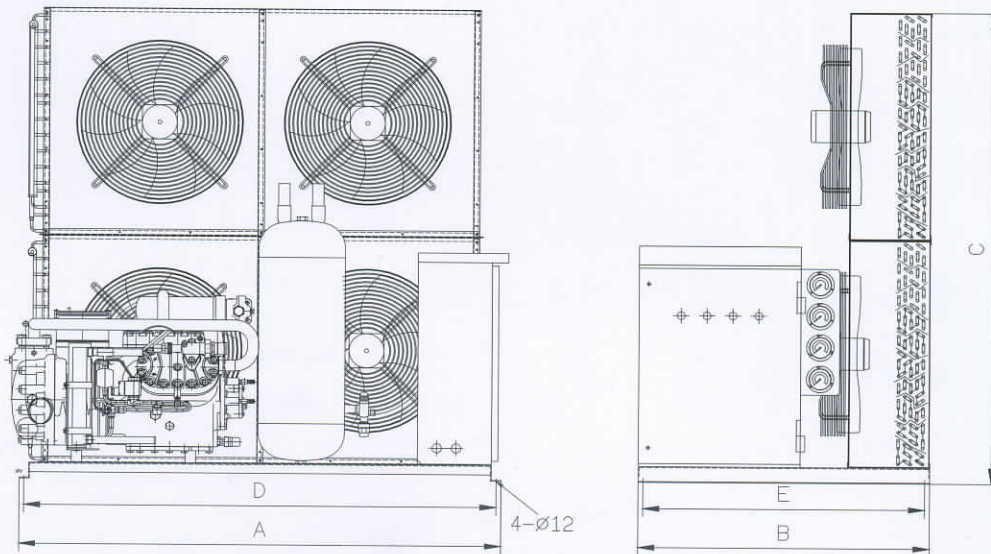

室外机机型		Outdoor unit model		KLAC-D20SB			
电源	Power source	V	3 ϕ - 380- 50Hz				
库温	Room temperature	$^{\circ}\text{C}$	-45 $^{\circ}\text{C}$	配管尺寸 Piping dim	液管 Liquid line	mm	22.22 (ϕ 7/8")
冷却能力	Cooling capacity	kcal/hr	9240		低压管 Suction line	mm	41.28 (ϕ 1 5/8")
消耗电力	Power consumption	kW	13.1	附属配件 Accessories		视窗、干燥器、储液器 Sight glass , Dryer , Receiver	
压缩机 Compressor	型式 Type	双段半密往复式 Two-stage Semi-hermetic Reciprocating					
	机数 Quantity	1					
	出力 Output	kW	14.9	保护装置 Protection devices		高低压开关、过载保护装置、 逆相保护器 High/low pressure switch, Overload pro	
	起动方式 Start method	直接起动 Direct starting					
	回转数 Revolution	r.p.m	2900				
油加热器 Oil heater	W	140					
冷冻油 Refrig. oil	种类 Type	BSE-32		外型尺寸 Dimension	A	mm	1500
	填充量 Charge quantity	L	4.8		B	mm	900
冷媒 Refrigerant	种类 Type	R-507 / R-404A		外型尺寸 Dimension	C	mm	1500
冷凝器 Condenser	型式 Type	鳍片式 Fin-tube type			D	mm	1470
	风扇数 Fan quantity	4		E	mm	870	
	散热风扇 Air flow rate	m^3/min	340		机组重量 Operating weight	kg	450

1. 以上规格依外气温度35 $^{\circ}\text{C}$ D B, 库内温度-45 $^{\circ}\text{C}$
2. 压缩机及控制可依客户需求订制
3. 如有特殊要求, 订货前请提出要求规范, 以上规格如有变更, 恕不另行通知

冷冻用双段冷冻机组

Condensing unit and cooler

R507/R404A 冷冻

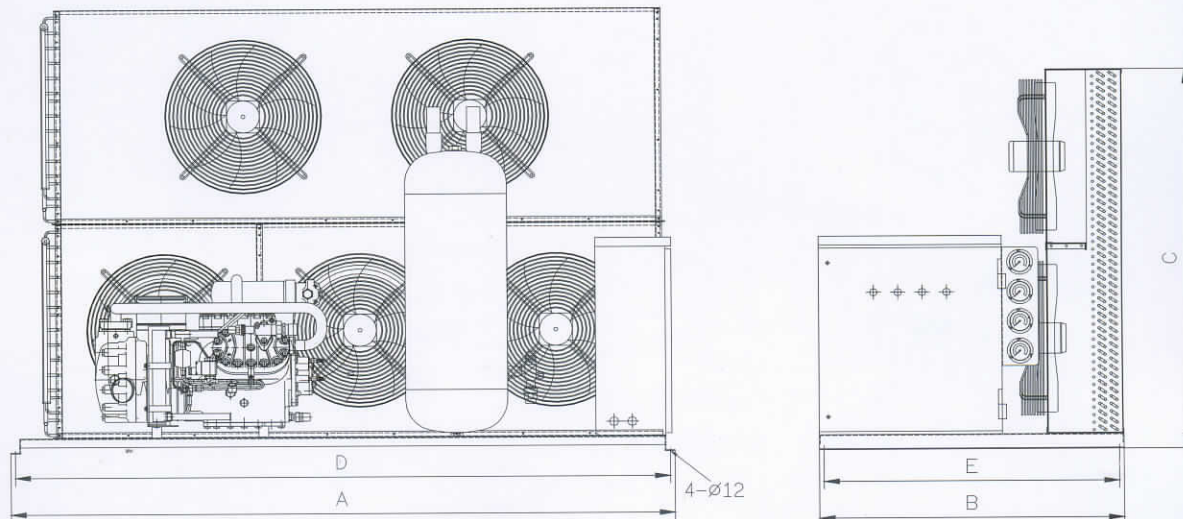

室外机机型		Outdoor unit model		KLAC-D25SB						
电源	Power source	V	3 ϕ - 380- 50Hz							
库温	Room temperature	$^{\circ}\text{C}$	-45 $^{\circ}\text{C}$	配管尺寸 Piping dim	液管 Liquid line	mm	22.22(ϕ 7/8")			
冷却能力	Cooling capacity	kcal/hr	10570		低压管 Suction line	mm	41.28 (ϕ 1 5/8")			
消耗电力	Power consumption	kW	15.2	附属配件 Accessories		视窗、干燥器、储液器 Sight glass , Dryer , Receiver				
压缩机 Compressor	型式	Type	双段半密往复式 Two-stage Semi-hermetic Reciprocating							
	机数	Quantity	1							
	出力	Output	kW					18.6		
	起动方式 Start method		直接起动 Direct starting					保护装置 Protection devices	高低压开关、过载保护装置、 逆相保护器 High/low pressure switch, Overload pro	
	回转数	Revolution	r.p.m							
	油加热器	Oil heater	W	140						
冷冻油 Refrig. oil	种类	Type	BSE-32	外型尺寸 Dimension	A	mm	2200			
	填充量 Charge quantity	L	4.8		B	mm	1000			
冷媒 Refrigerant	种类	Type	R-507 / R-404A		C	mm	1500			
	冷凝器 Condenser	型式	Type		鳍片式 Fin-tube type	D	mm	2170		
风扇数		Fan quantity			5	E	mm	970		
散热风扇 Air flow rate		m ³ /min		425	机组重量 Operating weight		kg	500		

1. 以上规格依外气温度35 $^{\circ}\text{C}$ DB, 库内温度-45 $^{\circ}\text{C}$
2. 压缩机及控制可依客户需求订制
3. 如有特殊要求, 订货前请提出要求规范, 以上规格如有变更, 恕不另行通知

冷冻用双段冷冻机组

Condensing unit and cooler

R507/R404A 冷冻

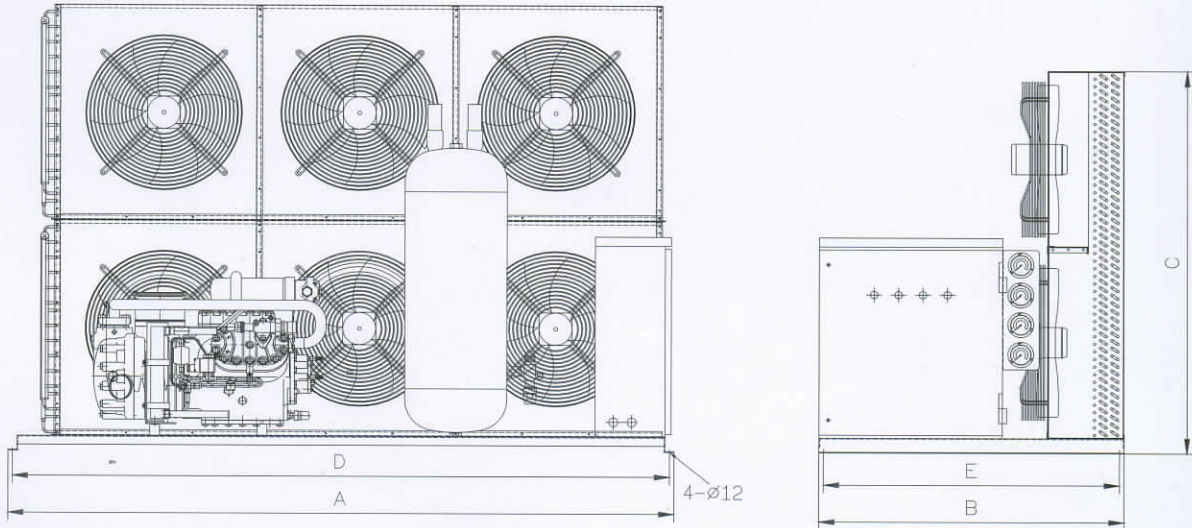

室外机机型		Outdoor unit model		KLAC-D30SB			
电源	Power source	V	3 φ - 380- 50Hz				
库温	Room temperature	°C	-45°C	配管尺寸 Piping dim	液管 Liquid line	mm	22.22 (φ 7/8")
冷却能力	Cooling capacity	kcal/hr	12580		低压管 Suction line	mm	41.28 (φ 1 5/8")
消耗电力	Power consumption	kW	17.2	附属配件 Accessories		视窗、干燥器、储液器 Sight glass , Dryer , Receiver	
压缩机 Compressor	型式 Type		双段半密往复式 Two-stage Semi-hermetic Reciprocating				
	机数 Quantity		1				
	出力 Output	kW	18.6	保护装置 Protection devices		高低压开关、过载保护装置、 逆相保护器 High/low pressure switch, Overload pro	
	起动方式 Start method		直接起动 Direct starting				
	回转数 Revolution	r.p.m	2900				
油加热器 Oil heater	W	140					
冷冻油 Refrig. oil	种类 Type		BSE-32	外型尺寸 Dimension	A	mm	2200
	填充量 Charge quantity	L	4.8		B	mm	1000
冷媒 Refrigerant	种类 Type		R-507 / R-404A		C	mm	1500
	型式 Type		鳍片式 Fin-tube type		D	mm	2170
冷凝器 Condenser	风扇数 Fan quantity		6		E	mm	970
	散热风扇 Air flow rate	m³/min	510	机组重量 Operating weight		kg	550

1. 以上规格依外气温度35°C DB, 库内温度-45°C
2. 压缩机及控制可依客户需求订制
3. 如有特殊要求, 订货前请提出要求规范, 以上规格如有变更, 恕不另行通知

水冷式冷冻用双段冷凝机组

Water-cooled condensing unit for refrigeration

R507/R404A 冷冻

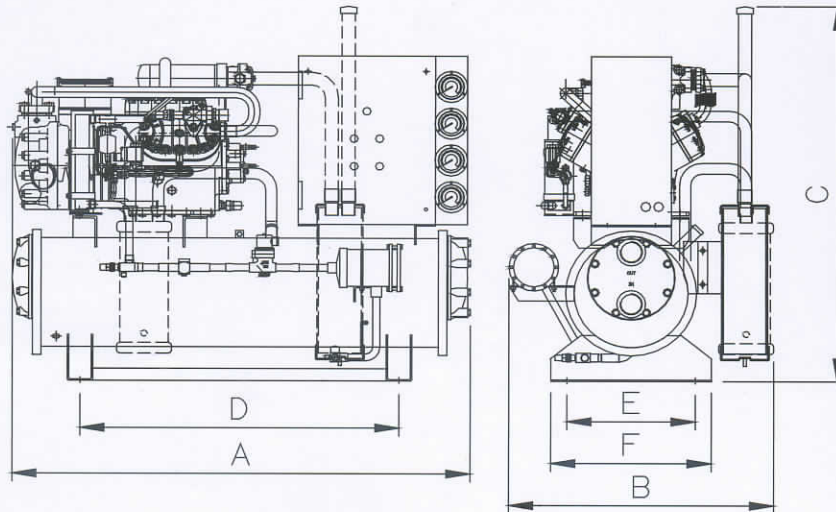

机型	Model		KLCC-015S	KLCC-020S	KLCC-025S	KLCC-030S
电源	Power source	V	3 ϕ - 380- 50Hz			
蒸发温度	Evaporation temperature	°C	-45°C			
冷却能力	Cooling capacity	kcal/hr	11,500	13,000	15,000	18,000
消耗电力	Power consumption	kW	9.80	11.7	13.4	16.1
380V运转电流	Running ampere	A	18	21	24	29
压缩机 Compressor	型式	Type	双段半密往复式 Two-stage Semi-hermetic Reciprocating			
	机数	Quantity	1			
	起动方式	Start method	直接起动 Direct starting			
	回转数	Revolution	r.p.m 2900			
	油加热器	Oil heater	W 140			
冷冻油 Refrig. oil	种类	Type	BSE-32			
	填充量	Charge quantity	L 4.8	4.8	4.8	4.8
冷媒 Refrigerant	种类	Type	R-507 / R-404A			
	型式	Type	壳管式 Shell and tube			
冷凝器 Condenser	管径	Pipe size	inch 2"	2"	2 1/2"	2 1/2"
	冷却水量	Water flow rate	m ³ /hr 9.4	12.5	15.7	18.8
配管尺寸 piping dim	液管	Liquid line	mm 5/8"	7/8"	7/8"	7/8"
	低压管	Suction line	mm 1 5/8"	1 5/8"	1 5/8"	1 5/8"
附属配件	Accessories		视窗、干燥器、储液器 Sight glass, Dryer, Receiver			
保护装置	Protection devices		高低压开关、过载保护装置、逆相保护器 High/low pressure switch, Overload pro			
外型尺寸 Dimension	A		1650	1650	1500	1500
	B	mm	800	800	850	850
	C	mm	1250	1250	1250	1250
	D	mm	1000	1000	1000	1000
	E	mm	400	400	400	400
	F	mm	500	500	500	500
机组重量	Operating weight	kg	380	450	500	550

1. 以上规格依冷却水入口温度30°C，出口温度35°C，蒸发温度-45°C
2. 压缩机及控制可依客户需求订制
3. 如有特殊要求，订货前请提出要求规范，以上规格如有变更，恕不另行通知

水冷式冷冻用双段冷凝机组

Water-cooled condensing unit for refrigeration

R507/R404A 冷冻

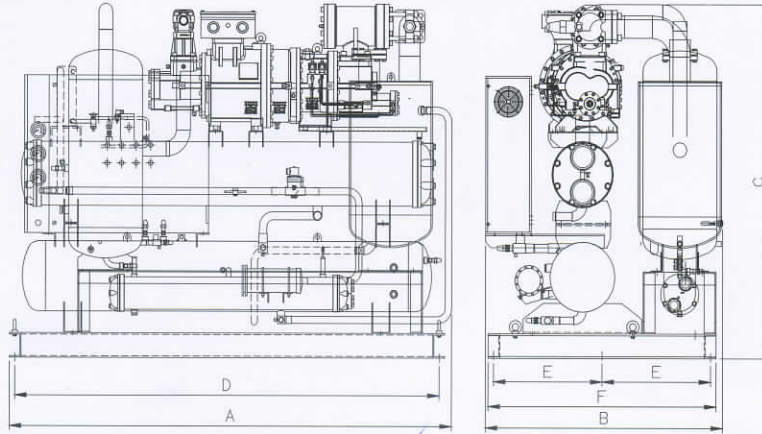

机型	Model		KLSC-040S	KLSC-075S	KLSC-100S	KLSC-125S	KLSC-175S	KLSC-200S	
电源	Power source	V	3 ϕ - 380- 50Hz						
蒸发温度	Evaporation temperature	°C	-45°C						
冷却能力	Cooling capacity	kcal/hr	21,500	41,000	60,000	82,000	101,000	121,000	
消耗电力	Power consumption	kW	18.5	32.6	47.7	64.7	79.7	94.7	
380V运转电流	Running ampere	A	33	58	85	115	141	168	
压缩机 Compressor	型式	Type	双段半密螺旋式 Two-stage Semi-hermetic Screw						
	机数	Quantity	1						
	起动方式	Start method	Y-Direct starting						
	回转数	Revolution	2900 / 3550						
	油加热器	Oil heater	300						
冷冻油 Refrig. oil	种类	Type	FS 035R						
	填充量	Charge quantity	L	19	20	21	27	28	29
冷媒 Refrigerant	种类	Type	R-507 / R-404A						
	型式	Type	壳管式 Shell and tube						
冷凝器 Condenser	管径	Pipe size	inch	PT3	PT3	PT4	PT4	5B	5B
	冷却水量	Water flow rate	m ³ /hr	25.1	47.1	62.7	78.4	109.8	125.5
配管尺寸 piping dim	液管	Liquid line	mm	1 1/8"	1 1/8"	1 3/8"	1 3/8"	1 5/8"	1 5/8"
	低压管	Suction line	mm	2 1/2"	2 1/2"	4"	4"	4"	4"
油冷却器 Oil cooling	型式	Type	壳管式 Shell and tube						
	管径	Pipe size	inch	PT 1 1/2	PT 1 1/2	PT 1 1/2	PT 2	PT 2	PT 2
	冷却水量	Water flow rate	m ³ /hr	1.5	2.5	3.7	5.0	6.3	7.6
附属配件	Accessories		视窗、干燥器、储液器 Sight glass , Dryer , Receiver						
保护装置	Protection devices		高低压开关、过载保护装置、逆相保护器 High/low pressure switch, Overload pro						
外型尺寸 Dimension	A		1850	2400	2438	2700	3000	3000	
	B	mm	1200	1300	1350	1350	1450	1550	
	C	mm	1550	1700	1850	1950	2150	2150	
	D	mm	1740	2340	2340	2540	2540	2540	
	E	mm	450	570	595	620	645	670	
	F	mm	1000	1200	1250	1300	1350	1400	
机组重量	Operating weight	kg	1100	1300	1900	2100	2500	2800	

1. 以上规格依冷却水入口温度30°C，出口温度35°C，蒸发温度-45°C
2. 压缩机及控制可依客户需求订制
3. 如有特殊要求，订货前请提出要求规范，以上规格如有变更，恕不另行通知

农畜类产品储存参考资料 (The storage reference data of agricultural and animal products)

项目(item) 食品名称 (food name)	储存温度 (storage temperature)	相对湿度 (relative humidity)	保存期限 (retention period)	含水量 (moist contents)	冻结点 (freeze point)	比热(specific heat)		冻结潜热 (freeze latent heat)
						冻结点以上 (Above freezing point)	冻结点以下 (Below freezing point)	
	(°C)	(%)	(°C)	(%)	(°C)	(kCal/kg)	(kCal/kg)	(kCal/kg)
牛肉(新鲜)(fresh beef)	0~1.1	88~92	1~6周(weeks)	62~77	-2.2~-1.7	0.7~0.84	0.38~0.43	49.4~61.1
牛肉(冷冻)(frozen beef)	-23.3~-17.8	90~95	9~12个月(months)					
猪肉(新鲜)(fresh pork)	0~1.1	85~90	3~7天(days)	35~44	-2.2~-1.7	0.46~0.55		25.6~35
猪肉(冷冻)(frozen pork)	-23.3~-17.8	90~95	4~6个月(months)				0.3~0.33	
羊肉(新鲜)(fresh mutton)	0~1.1	80~90	5~12天(days)	60~70	-2.2~-1.7	0.68~0.76	0.38~0.51	47.8~55.6
羊肉(冷冻)(frozen mutton)	-23.3~-17.8	90~95	8~10个月(months)					
兔肉(新鲜)(fresh rabbit meat)	0~1.1	90~95	1~5天(days)	68		0.74	0.4	54.4
兔肉(冷冻)(frozen rabbit meat)	-23.3~-17.8	90~95	6个月(months)					
家禽(新鲜)(fresh poultry)	0	85~90	1周(weeks)	74	-2.8	0.79		58.9
家禽(冷冻)(frozen poultry)	-28.9~-17.8	90~95	9~10个月(months)				0.42	
火腿(新鲜)(fresh ham)	0~1.1	85~90	7~12天(days)	47~54	-2.2~-1.7	0.58~0.63	0.34~0.36	37.2~42.8
火腿(冷冻)(frozen ham)	-23.3~-17.8	90~95	6~8个月(months)					
熏肉(新鲜)(fresh side meat)	-23.5~-18	90~95	4~6天(days)					
熏肉(烟熏)(side meat)	15.6~18.3	85	4~6个月(months)	13~29		0.3~0.43	0.24~0.29	10~22.8
香肠(wurst)	4.5~7	85~90			-4	0.86	0.56	39.4
奶油(butter)	-17.8~-23.3	80~85	1年(year)	15.5~16.5			0.25	12.8
乳酪(cheese)	-0.6~7.2	65~70		37~38		0.5	0.31	30
猪油(lard)	7.2	90~95	4~8个月(months)			0.52	0.31	50
腌肉(salting beef)	-0.6~0					0.75	0.36	41.7
蛋(有壳)(crusty egg)	-1.7~-0.6	80~85	6~9个月(months)	66	-2.2	0.73	0.4	53.3
蛋(冷冻)(frozen egg)	-17.8(以下)		1年以上(year)	74			0.42	58.9
蛋白(glair)	1.5	较低(lower)	6个月(months)	6		0.25	0.21	5
蛋黄(yolk)	1.7~4.4	较低(lower)	6~12个月(months)	3~5		0.23	0.21	3.3

蔬菜水果类产品储存参考资料 (The storage reference data of fruits and vegetables)

项目(item) 食品名称 (food name)	储存温度 (storage temperature)	相对湿度 (relative humidity)	保存期限 (retention period)	含水量 (moist contents)	冻结点 (freeze point)	冻结点以上 (Above freezing point)	比热(specific heat)		呼吸热 (respiration heat)
							冻结点以下 (Below freezing point)	冻结潜热 (freeze latent heat)	
	(°C)	(%)	(°C)	(%)	(°C)	(kCal/kg)	(kCal/kg)	(kCal/kg)	(kCal/kg)
芦笋(asparagus)	0	90~95	2~3周(weeks)	93	-0.6	0.94	0.48	74.4	2890
空心菜(water celery)	0	90~95	3~4个月(months)	92.4	-0.4	0.94	0.47	74	687
菜豆(干)(kidney bean)	2~4.5	70	6个月(months)	12		0.3	0.24	10	
甜菜(beet)	0	90~95	10~14天(days)		0.5				
胡萝卜(carrot)	0	90~95	4~5个月(months)	88.2	-1.4	0.9	0.46	70	
芹菜(celery)	-0.6~0	90~95	2~4个月(months)	93.7	-0.5	0.95	0.48	75	
马铃薯(potato)	3.3~10	85~90	2个月(months)	77.8	-0.6	0.82	0.43	61.7	358
菠菜(spinach)	0	90~95	10~14天(days)	92.7	-0.3	0.94	0.48	73.3	
番茄(tomato)	7.2~10	85~90	2~7天(days)	94.1	-0.5	0.95	0.48	74.4	1560
米(rice)	1.7	65	6个月(months)	10	-1.1	0.25			
苹果(apple)	-1.1~0	85~90	2~7个月(months)	84.1	-1.5	0.87	0.45	67.2	358
香蕉(banana)	13以上	85~95	数日(weeks)	74.8	-0.8	0.8	0.42	60	
樱桃(chery)	-0.6~0	85~90	10~14天(days)	83	-1.8	0.87	0.45	66.7	
柚子(shaddock)	10	85~90	4~8周(weeks)	88.8	-1.1	0.91	0.46	70	
梨子(pear)	-0.6~0	80~85	3~4周(weeks)	85.7	-0.8	0.88	0.45	68.3	192
桃子(peach)	-0.6~0	85~90	2~4周(weeks)	86.9	-0.9	0.9	0.46	68.9	432
草莓(strawberry)	-0.6~0	85~90	7~10天(days)	89.9	-0.8	0.92	0.42	71.7	
橘子(orange)	0~1.1	85~90	8~10周(weeks)	87.2	-0.8	0.9	0.46	68.9	

海产类产品储存参考资料 (The storage reference data of seafoods)

食品名称 (food name)	项目 (item)		保存期限 (retention period)	含水量 (moist contents)	冻结点 (freeze point)	比热 (specific heat)		冻结潜热 (freeze latent heat)
	储存温度 (storage temperature)	相对湿度 (relative humidity)				冻结点以上 (Above freezing point)	冻结点以下 (Below freezing point)	
	(°C)	(%)				(kCal/kg)	(kCal/kg)	
新鲜鱼 (fresh fish)	0.6~1.7	90~95	5~15天(days)	62~85	-2.2	0.7~0.86		49.4~67.8
冷冻鱼 (frozen fish)	-23.3~-17.8	90~95	8~10个月(months)	62~85			0.38~0.45	49.4~67.8
熏鱼 (bloat fish)	4.4~10	50~60	6~8个月(months)			0.7	0.39	51.5
干鱼 (dry fish)	-1~4.5	60~70					0.42	
龙虾 (lobster)	-3.9~4.4	80	1个月(months)	76		0.81	0.42	58.3
牡蛎 (oyster)	0~-1.7	90	2个月(months)	80	-5	0.85	0.45	66.7
鳕鱼 (hake)	-3.9	85	2周(weeks)	83	-1.7	0.76		
鲷鱼 (pompano)	0	78	1周(weeks)	45		0.56		36
旗鱼 (sailfish)	-9.5	78	3周(weeks)	45		0.56		36

其它类产品储存参考资料 (The storage reference data of other kind of foods)

食品名称 (food name)	项目 (item)		保存期限 (retention period)	含水量 (moist contents)	冻结点 (freeze point)	比热 (specific heat)		冻结潜热 (freeze latent heat)
	储存温度 (storage temperature)	相对湿度 (relative humidity)				冻结点以上 (Above freezing point)	冻结点以下 (Below freezing point)	
	(°C)	(%)				(kCal/kg)	(kCal/kg)	
巧克力糖 (chocolate)	20~21.1	50~55	6~8个月(months)					
蜂蜜 (honey)	-0.6~-10		1年以上(year)	18		0.35	0.26	14.4
动物油 (animal oil)	13		6个月(months)					
植物油 (plant oil)	1.5		1个月(months)			0.65		
人造奶油 (margarine)	13	60~70	6个月(months)		-9.4		0.34	19
冰淇淋 (ice cream)	-17.8~12.2	65	3个月(months)	67		0.5~0.8	0.45	53.3
啤酒 (beer)	1.7~4.4	90	3~10周(weeks)	90.2	-2.2	0.92		71.7
碳酸饮料 (carbonic acid drink)	-1.1~1.7	85	3个月(months)		-1.7	0.9		
糖浆 (sirup)	7	80	6周(weeks)	36	-2.2			
糖 (sugar)	7.2							
烈酒 (firewater)	4.5~7					0.3		
巧克力 (chocolate)	7.2~10	75	6个月(months)			0.3		
果酱 (catchup)	1.1	75	6个月(months)	36		0.48		



高雄厂 Kaohsiung Factory

地址：高雄市梓官区赤崁北路336号

Add: No. 336, Chin-Kan N. Road, Tzu-Kuan district, Kaohsiung, Taiwan

电话 Tel: +886-7-6192345 传真 Fax: +886-7-6193583

网址 [Http://www.kuenling.com.tw](http://www.kuenling.com.tw)

邮箱 E-mail: klmain@kuenling.com.tw

上海厂 Shanghai Factory

地址：上海市松江区九亭镇洋河浜路518号

Add: No. 518, YangHeBang Rd. Jiuting Town, SongJiang District, Shanghai, China

电话 Tel: +86-21-67696169 传真 Fax: +86-21-67696705

网址 [Http://www.kuenling.com](http://www.kuenling.com)

邮箱 E-mail: China@kuenling.com



吴江厂 Wujiang Factory

地址：江苏省苏州市吴江经济开发区江兴东路815号

Add: No. 815, JiangXing East Road Economic Development District, Wujiang, Suzhou, Jiangsu, China

电话 Tel: +86-512-63406188 传真 Fax: +86-512-63406388

网址 [Http://www.kuenling.com](http://www.kuenling.com)

邮箱 E-mail: kuenyuan@kuenling.com

越南厂 Vietnam Factory

地址：隆安省德和县新德工业区七路10-12号

Add: So 10-12, Duong so 7, KCN Tan Duc, Xa Duc Hoa Ha, Huyen Duc Hoa, Tinh Long An, Vietnam

电话 Tel: +84-72-3769080 传真 Fax: +84-72-63769083

网址 [Http://www.kuenling.com.tw](http://www.kuenling.com.tw)

邮箱 E-mail: klmain@kuenling.com.tw



莒霖官方微信号

本样本版权属于莒霖冷冻机械(上海)有限公司所有, 数据如有更新, 恕不另行通知

版本号: KT-000162.A-01-CN-CABG